



PLATFORMS $\frac{5400 \text{ mm}}{6000 \text{ mm}}$



VERTICAL RISE
From 5500 to 6500 kg

SF8000 SERIES

Sollevatori
elettroidraulici

IT

*Electro-
hydraulic lift*

EN

Elektrohydraulische
Hebebühnen

DE

*Elévateurs
electro-
hydrauliques*

FR

Elevadores
electrohidraulicos

ES

Sollevatori con pedane piane
Lifts with flat platforms
 Hebebühnen mit flachen Fahrstienen
Élévateurs avec chemins de roulement plats
 Elevadores con plataformas lisas



SF 8601.60 - 6500 kg / 6000 mm
SF 8601.60LT - 6500 kg / 6000 mm / LIFT TABLE

Sollevatori con pedane di grandi dimensioni e struttura portante studiata per la massima rigidità e stabilità in esercizio.

Lifts with large size platforms and sturdy structure assuring maximum rigidity and working stability.

Lange verstärkte Fahrbahnen bieten aufgrund der intelligenten Konstruktion eine hervorragende Steifigkeit.

Ponts élévateurs avec chemins de roulement de grandes dimensions et structure portante étudiée pour offrir un maximum de rigidité et de stabilité pendant le fonctionnement.

Elevadores con plataformas de grandes dimensiones y estructura portante estudiada para garantizar la máxima rigidez y estabilidad de trabajo.

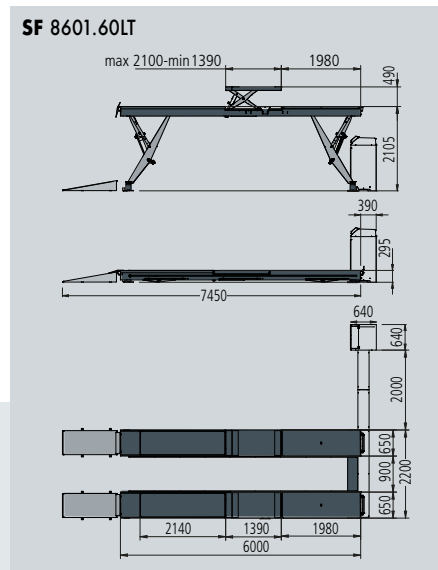
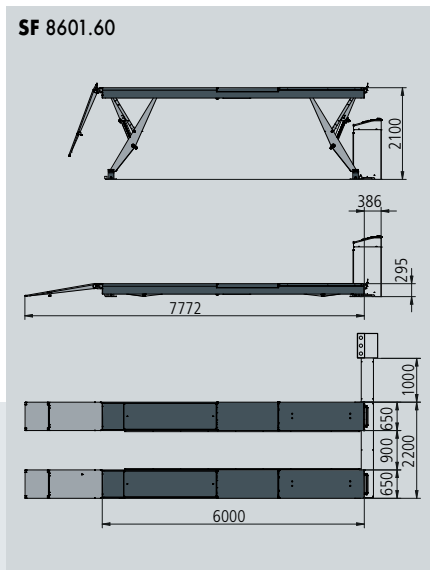

	Portata Capacity Tragfähigkeit Capacité Capacidad	Pedane Platforms Fahrstienen Plateformes Plataformas
	kg	mm
SF 8601.60	6.500	6000
SF 8601.60LT	6.500	6000



**CATAPHORESIS
 ANTI-CORROSION
 COATING**



Sollevatori per misurazione assetto ruote
Wheel alignment lifts
 Hebebühnen für die Achsvermessung
Elévateurs pour contrôle de géométrie
 Elevadores alineado de direccón

2

- SF 8502.54 - 5500 kg / 5400 mm
- SF 8502.54LT - 5500 kg / 5400 mm / LIFT TABLE
- SF 8602.60 - 6500 kg / 6000 mm
- SF 8602.60LT - 6500 kg / 6000 mm / LIFT TABLE

Pedane per assetto totale con sedi anteriori per piatti rotanti e piani oscillanti posteriori.

Platforms for total wheel alignment, with front turning plates locations and rear slip plates.

Fahrschiene in Achsmessausführung, mit vorderer Drehtellerfassung und hinterer Schiebepatte.

Chemins de roulement pour géométrie totale, avec logements avant pour plateaux pivotants et plans mobiles arrière.

Plataformas para alineación total, con asientos para platos giratorios delanteros y platos oscilantes traseros.

SF 8502.54

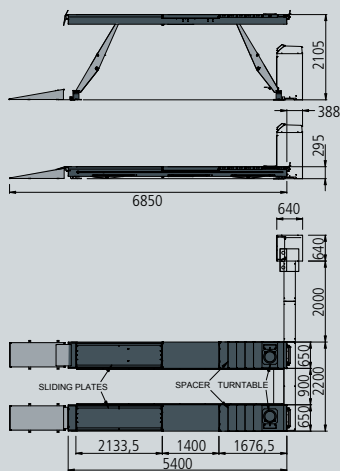

SF 8502.54LT

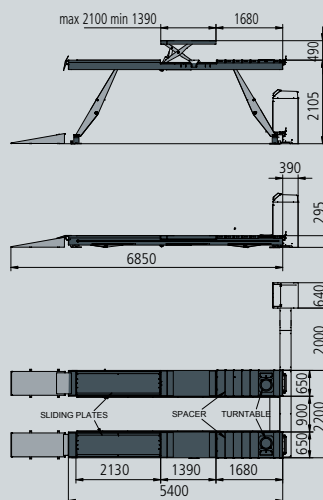

LT MODELS
LIFT TABLE - 4000 kg



SF 8602.60

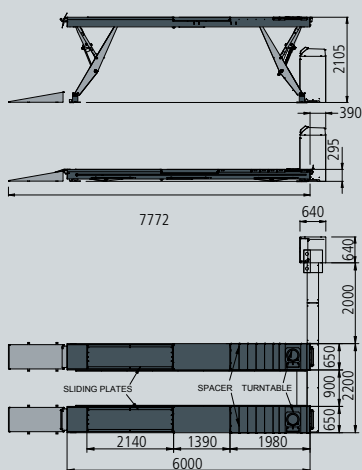

SF 8602.60LT

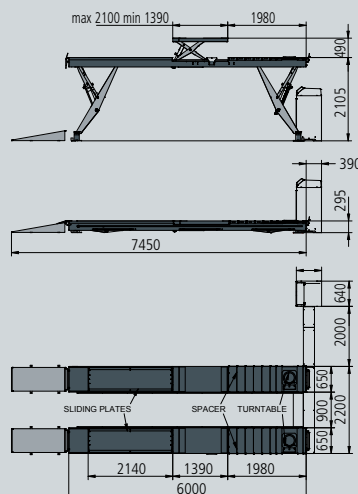

	Portata Capacity Tragfähigkeit Capacité Capacidad	Pedane Platforms Fahrschienen Plateformes Plataformas
	kg	mm
SF8502.54	5.500	5400
SF8502.54LT	5.500	5400
SF8602.60	6.500	6000
SF8602.60LT	6.500	6000



COMPANY WITH
QUALITY SYSTEM
CERTIFIED BY DNV GL
= ISO 9001 =

Versioni incassate
Recessed versions
Unterflurausführungen
Versions à encastrement
Versiones empotradas



Tutti i sollevatori possono essere forniti anche in versione incassata.

All can be supplied for recessed installation.

Alle Hebebühnen können auch in Unterflur-Version geliefert werden.

Tous les ponts élévateurs peuvent être fournis en version encastrée dans le sol.

Todos los elevadores se encuentran disponibles en versión empotrada.

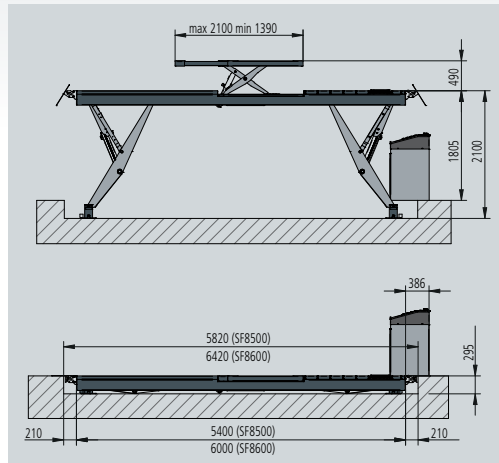

	Portata Capacity Tragfähigkeit Capacité Capacidad	Pedane Platforms Fahrstufen Plateformes Plataformas
	kg	mm
SF8601.60I	6.500	6000
SF8601.60ILT	6.500	6000
SF8502.54I	5.500	5400
SF8502.54ILT	5.500	5400
SF8602.60I	6.500	6000
SF8602.60ILT	6.500	6000

OPTIONS

Vedere documentazione specifica - See special technical specifications - Siehe spezifische Unterlagen - Voir documentation spécifique - Consultar documentación específica



S8000A1 (2 x kit)

Supporti per assetto 3D
Brakets for 3D alignment
Halter für 3D Achsmessgeräte
Supports pour géométrie 3D
Soportes para alineadoras 3D

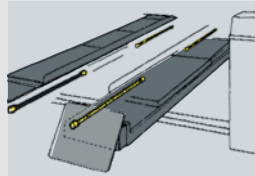

Impianto di illuminazione
Lighting kit
Beleuchtung
Système d'éclairage
Instalación de alumbrado



OPTIONS LT

S505A2 (2 x kit)

Traverse

Indispensabili per il sollevamento in sicurezza a ruote libere di fuoristrada e veicoli particolari con punti di sollevamento su pianale ravvicinati.

Cross members

To provide safe wheel free lifting of vehicles with narrow lifting points.

Querstreben

Für ein sicheres Anheben von Geländewagen und Sonderfahrzeugen mit Radfreihebern an aneinander angenäherten Hebepunkten auf der Hebebühne.

Traverses pour véhicules spéciaux

Indispensables pour le levage en toute sécurité avec roues libres de véhicules tout-terrain et véhicules avec points de levage rapprochés à l'intérieur du chassis.

Traviesas para vehículos especiales

Indispensables para el levantamiento "ruedas libres" en condiciones de seguridad de vehículos todo terreno y vehículos con puntos de levantamiento al interior del chasis.

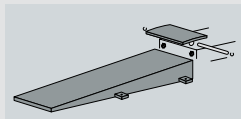

Rampe lunghe
Longer run-up ramps
Längere Auffahrampen
Rampes d'accès longues
Rampas de subida largas



Traverse
Jacking beams
Achsheber
Traverses
Gatos

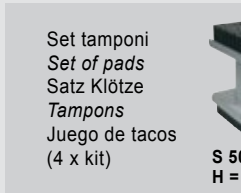

Set tamponi
Set of pads
Satz Klötze
Tampons
Juego de tacos
(4 x kit)

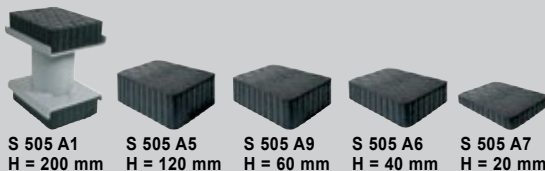

SPACE s.r.l. a s.u.

Via Sangano, 48
10090 Trana - Torino - ITALY
tel. +39-011-934.40.300
fax +39-011-933.88.64
e-mail: info@spacetest.com
www.spacetest.com

Member of VSG - Vehicle Service Group
a company

Le caratteristiche tecniche e gli allestimenti presentati in questo prospetto possono subire variazioni. Le immagini riprodotte non sono vincolanti.
Technical data and composition presented in this catalogue may vary.
Pictures reproduced are only indicative.
Die techn. Daten und die Ausstattungen, die in diesem Prospekt enthalten sind, können Änderungen erfahren. Deshalb sind die Abbildungen unverbindlich.
Les caractéristiques techniques et les compositions présentées dans ce prospect peuvent subir des variations. Les images reproduites n'ont qu'une valeur indicative.
Las características técnicas y las composiciones ilustradas en este folleto pueden sufrir variaciones. Las imágenes propuestas son solamente indicativas.

DTD26U (06)