



GGRS 926.MOVI HYDRAULIC TILTING

Smontagomme autocarro retrattile, adatto sia a furgoni chiusi che a furgoni telonati. Ideale per assistenza pneumatici su strada, può operare sia su pneumatici autocarro che agricoli. Azionamenti elettroidraulici. Comandi bluetooth. Mandrino idraulico.

Retractable truck tyre changer suitable for closed vans. Ideal for road-side tyre service, it is suitable for both truck and also for agricultural tyres. Electro-hydraulic movements. Bluetooth controls. Hydraulic chucking table.

Einfahrbares LKW-Montiergerät, geeignet für Lieferwagen und geschlossene Anhänger. Ideal für den Serviceeinsatz auf der Strasse, es kann sowohl LKW- als auch Landwirtschaftsräder montieren. Die Steuerung ist elektrohydraulisch. Steuerung mit Bluetooth Verbindung. Hydraulische Spannvorrichtung.

Démonte-pneus PL rétractile, apte soit aux fourgons fermé qui aux fourgons bâchés. Idéal pour assistance pneus sur rue, il peut opérer soit sur pneumatiques PL que agricoles. Actionnements électro-hydrauliques. Commandes avec transmission bluetooth. Mandrin hydraulique.

Desmontadora para camiones retráctil, ideal para furgonetas cerradas o furgonetas con toldo carrozadas. Perfecta para asistencia de neumáticos en carretera, puede operar tanto con neumáticos para camiones cuanto con neumáticos agrícolas. Movimientos electrohidráulicos. Mandos por vía Blue Tooth. Plato mandril hidráulico.

HYDRAULIC WHEEL CLAMPING



MINIMUM CLAMPING Ø 90 MM (3,5")



STAND-BY FUNCTION

Dopo 5 secondi di inutilizzo il motore si spegne.
After 5 sec. of no use, the motor turns off.
 Bei nicht Benutzung geht nach 5 Sek. das Aggregat in Standby.
Après 5 secondes sans utilisation le moteur s'éteint.
 Después de 5 segundos de no utilizzo el motor se apaga.

GGRS926.MOVI

Smontagomme autocarro

(IT)

Truck tyre changers

(EN)

LKW-Montiermaschinen

(DE)

Démonte-pneus poids lourds

(FR)

Desmontadoras camiones

(ES)



COMPANY WITH
QUALITY SYSTEM
CERTIFIED BY DNV GL
= ISO 9001 =

EASY SETTING



Hydraulic Up-Down Movement
MINIMUM HEIGHT 330 mm (13")
→ on 500mm vehicle surface

EASY CLAMPING



Hydraulic In-Out Movement

QUICK DEMOUNTING



QUICK MOUNTING



VARGNAV26BT



Variante per comandi Bluetooth
Version with Bluetooth controls

OPTIONS



G108A2
Alu protection
(4 x kit)



G90A6
Alu rim clamp

GGRS926.MOVI

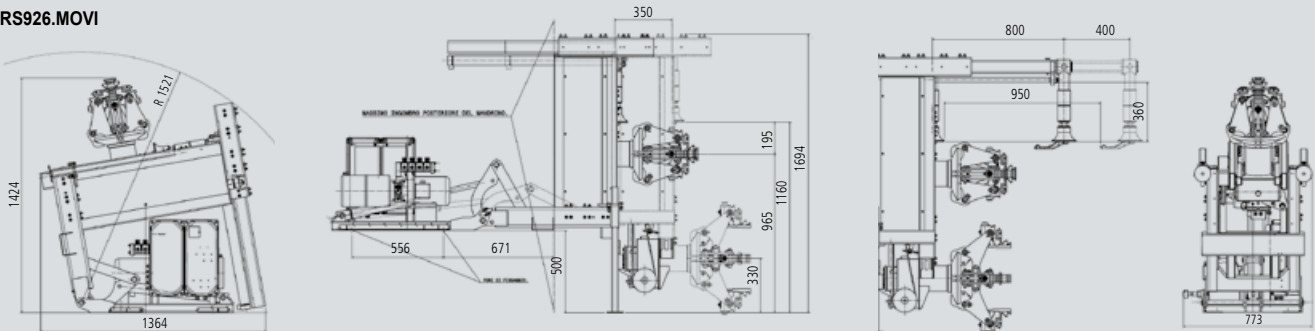

DATI TECNICI	TECHNICAL DATA	TECHNISCHE DATEN	DONNEES TECHNIQUES	DATOS TÉCNICOS	GGRS926.MOVI	
Motore rotazione mandrino	Chucking unit rotation motor	Motor für Drehung der Spannvorrichtung	Moteur rotation mandrin	Motor rotación plato	kW	1,5
Motore centralina	Hydraulic drive unit motor	Hydraulikmotor	Moteur de la pompe	Motor unidad hidráulica	kW	2,2
Ø cerchi	Rim Ø	Felgen-Ø	Ø de la jante	Ø de llantas en pulgadas		11"-27"
Ø est. ruota ammesso	Max. wheel Ø	Raddurchmesser	Ø de la roue	Ø maximo ext. rueda		1300 mm (51")
Larghezza max. ruota	Max. allowed wheel width	Max. Radbreite	Largeur maxi de la roue	Ancho max. rueda		950 mm (37.4")
Peso	Weight	Gewicht	Poids	Peso		403 kg/888 lb
Potenza stallatore	Bead breaker power	Abdrückerkraft	Force du détalonneur	Force du détalonneur	N	16000
Peso max ruota	Max wheel weight	Maximales Radgewicht	Poids maxi de la roue	Poids maxi de la roue		1200 kg/2645 lbs
Velocità di rotazione mandrino (giri/min)	Chuck rotation speed (rev/min)	Sperrvorrichtungs-Drehgeschwindigkeit (U./min.)	Vitesse de rotation du mandrin (tours/min.)	Velocidad de rotación mandrín (rev./min.)		8
Coppia max al mandrino	Max. torque to chuck	Max. Sperrvorrichtungs-Drehmoment	Couple max. au mandrin	Par máx al mandrín		2200 Nm (1620 FtLbs)

SPACE s.r.l. a s.u.

Via Sangano, 48
10090 Trana - Torino - ITALY
tel. +39-011-934.40.300
fax +39-011-933.88.64
e-mail: info@spacetest.com
www.spacetest.com

Le caratteristiche tecniche e gli allestimenti presentati in questo prospetto possono subire variazioni. Le immagini riprodotte non sono vincolanti. Technical data and composition presented in this catalogue may vary. Pictures reproduced are only indicative.

Die techn. Daten und die Ausrüstungen, die in diesem Prospekt enthalten sind, können Änderungen erfahren. Deshalb sind die Abbildungen unverbindlich.

Les caractéristiques techniques et les compositions présentées dans ce prospectus peuvent subir des variations. Les images reproduites n'ont qu'une valeur indicative.

Las características técnicas y las composiciones ilustradas en este folleto pueden sufrir variaciones. Las imágenes propuestas son solamente indicativas.

CE DTN11U (01)