

Smontagomme autocarro per servizio mobile o in officina, adatta a furgoni telonati o piccole officine. Comandi su consolle.

Truck tyre changer for both road-side and workshop service, suitable for closed vans and/or small workshops. Controls on console.

Montiergerät für den mobilen oder stationären Einsatz, geeignet für geschlossene Anhänger oder Kleinwerkstätte. Pultsteuerung.

Démonte-pneus PL pour service mobile ou en atelier. Il adapte aux fourgons bâchés ou pour petits ateliers. Commandes sur console.

Desmontadora para camiones para servicio móvil o para servicio en el taller, ideal para furgonetas con toldo carrozadas o pequeños talleres. Mandos en la consola.



TUBE AND TUBELESS



GGRS926

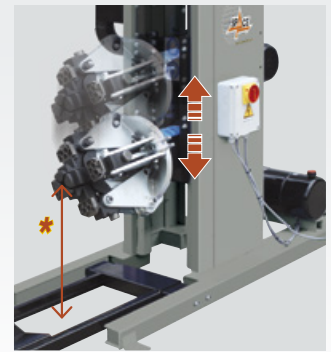

\* MINIMUM HEIGHT  
330 mm (13")

\* MINIMUM CLAMPING  
Ø 90 mm (4")

HYDRAULIC UP-DOWN  
MOVEMENT



EASY SETTING



## GGRS926 HYDRAULIC CLAMPING

Mandrino idraulico. Adatta anche a pneumatici agricoli.

Hydraulic chucking table. Suitable also for agricultural tyres.

Hydraulische Spannvorrichtung. Geeignet auch für Landwirtschaftsräder.

Mandrin hydraulique. Apte aussi au pneus agricoles.

Plato mandril hidráulico. Puede ser utilizada con ruedas agrícolas también.

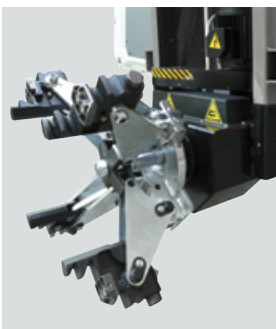

## GGRS926 SERIES

Smontagomme per servizio mobile o in officina

(IT)

Tyre changer for road-side and workshop service

(EN)

Montiergerät für den mobilen oder stationären einsatz

(DE)

Démonte-pneus pour service mobile ou en atelier

(FR)

Desmontadora para servicio móvil o en el taller

(ES)

**OPTIONS**

(GGRS926.ST)



**GTB10A1**

Bloccaggio cerchi con Ø foro centrale 160-175-200 mm.  
*Rim locking accessories with centre hole Ø 160-175-200 mm.*  
 Arretierung von Felgen mit Mittenloch Ø 160-175-200 mm.  
*Blocage des jantes avec Ø central 160-175-200 mm.*  
 Bloqueo de las llantas con Ø agujero central de 160-175-200 mm.



**GTB10A2**

Bloccaggio cerchi con foro centrale Ø da 57 a 141 mm.  
*Rim locking accessories with centre hole Ø from 57 to 141 mm.*  
 Arretierung von Felgen mit Mittenloch Ø von 57 bis 141 mm.  
*Blocage des jantes avec Ø central de 57 à 141 mm.*  
 Bloqueo de las llantas con Ø agujero central de 57 hasta 141 mm.



**COMPANY WITH  
 QUALITY SYSTEM  
 CERTIFIED BY DNV GL  
 = ISO 9001 =**

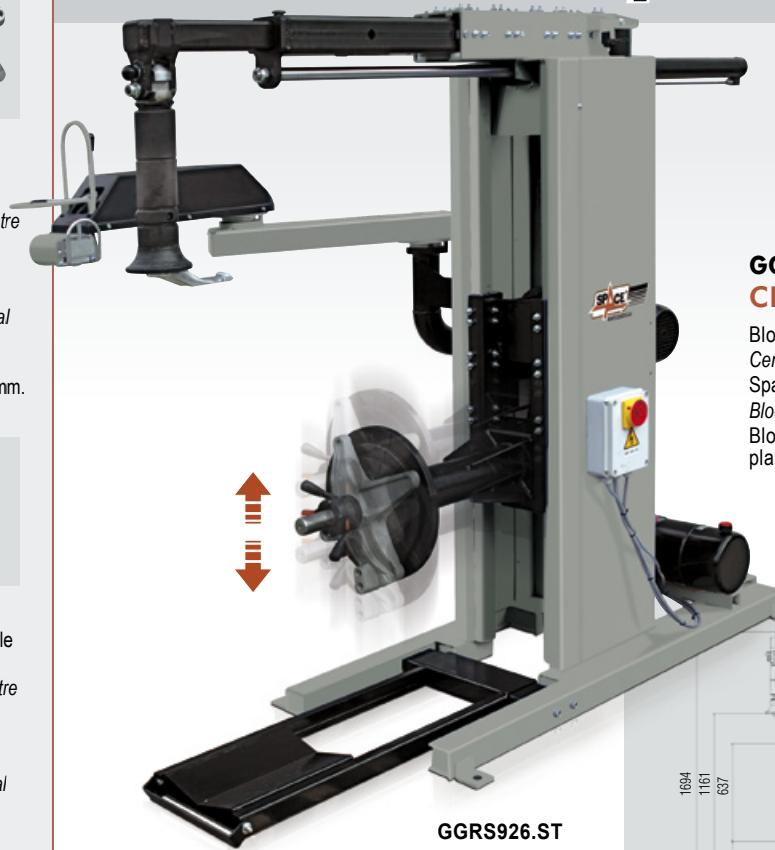

**GGRS926.ST  
 CENTER LOCKING**

Bloccaggio centrale a ghiera  
*Central docking with ring nut.*  
 Spannvorrichtung mit Fixiermutter.  
*Blocage central par flasque.*  
 Bloqueo central a través de platos/conos.

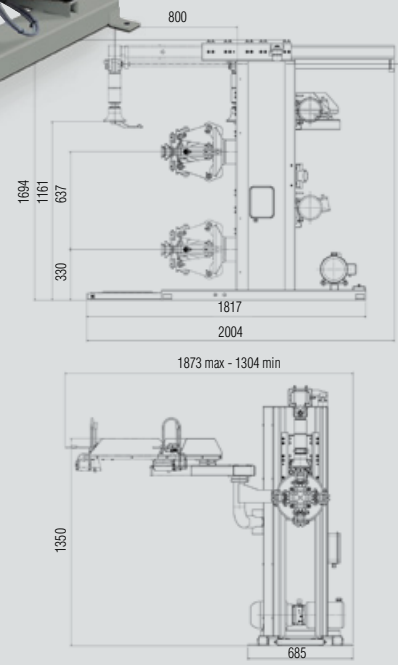

**OPTIONS**

(GGRS926)



**G108A2**  
 Alu Protection (4 X Kit)

(GGRS926 - GGRS926.ST)



**G90A6**  
 Alu Rim Clamp



**G108A22**  
 Disc for wheels with lock ring

DATI TECNICI	TECHNICAL DATA	TECHNISCHE DATEN	DONNEES TECHNIQUES	DATOS TÉCNICOS	GGRS926	GGRS926.ST
Motore rotazione mandrino	<i>Chucking unit rotation motor</i>	Motor für Drehung der Spannvorrichtung	<i>Moteur rotation mandrin</i>	Motor rotación plato	1,1 kW	
Motore centralina	<i>Hydraulic drive unit motor</i>	Hydraulikmotor	<i>Moteur de la pompe</i>	Motor unidad hidráulica	2 kW	
Ø cerchi	<i>Rim Ø</i>	Felgen-Ø	<i>Ø de la jante</i>	Ø de llantas en pulgadas	11"-27"	14"-27"
Ø est. ruota ammesso	<i>Max. wheel Ø</i>	Raddurchmesser	<i>Ø de la roue</i>	Ø maximo ext. rueda	1300 mm (51")	
Larghezza max. ruota	<i>Max. allowed wheel width</i>	Max. Radbreite	<i>Largeur maxi de la roue</i>	Ancho max. rueda	950 mm (37.4")	
Peso	<i>Weight</i>	Gewicht	<i>Poids</i>	Peso	378 kg/833 lb	340 kg/750 lb
Potenza stallonatore	<i>Bead breaker power</i>	Abdrückerkraft	<i>Force du détalonneur</i>	Force du détalonneur	16000 N	
Peso max ruota	<i>Max wheel weight</i>	Maximales Radgewicht	<i>Poids maxi de la roue</i>	Poids maxi de la roue	1200 kg/2645 lbs	
Velocità di rotazione mandrino (giri/min)	<i>Chuck rotation speed (rev/min)</i>	Sperrvorrichtungs-Drehgeschwindigkeit (U./min.)	<i>Vitesse de rotation du mandrin (tours/min.)</i>	Velocidad de rotación mandril (rev./min.)	8	
Coppia max al mandrino	<i>Max. torque to chuck</i>	Max. Sperrvorrichtungs- Drehmoment	<i>Couple max. au mandrin</i>	Par máx al mandril	1700 Nm (1253 FtLbs)	

**SPACE s.r.l. a s.u.**

Via Sangano, 48  
 10090 Trana - Torino - ITALY  
 tel. +39-011-934.40.300  
 fax +39-011-933.88.64  
 e-mail: info@spacetest.com  
 www.spacetest.com

Le caratteristiche tecniche e gli allestimenti presentati in questo prospetto possono subire variazioni. Le immagini riprodotte non sono vincolanti.  
*Technical data and composition presented in this catalogue may vary. Pictures reproduced are only indicative.*  
 Die techn. Daten und die Ausrüstungen, die in diesem Prospekt enthalten sind, können Änderungen erfahren. Deshalb sind die Abbildungen unverbindlich.  
 Les caractéristiques techniques et les compositions présentées dans ce prospectus peuvent subir des variations. Les images reproduites n'ont qu'une valeur indicative.  
 Las características técnicas y las composiciones ilustradas en este folleto pueden sufrir variaciones. Las imágenes propuestas son solamente indicativas.

