



Smontagomme autocarro per servizio mobile o in officina, adatta a furgoni telonati o piccole officine. Comandi su consolle.

Truck tyre changer for both road-side and workshop service, suitable for closed vans and/or small workshops. Controls on console.

Montiergerät für den mobilen oder stationären Einsatz, geeignet für geschlossene Anhänger oder Kleinwerkstätte. Pultsteuerung.

Démonte-pneus PL pour service mobile ou en atelier. Il adapte aux fourgons bâchés ou pour petits ateliers. Commandes sur console.

Desmontadora para camiones para servicio móvil o para servicio en el taller, ideal para furgonetas con toldo carrozadas o pequeños talleres. Mandos en la consola.

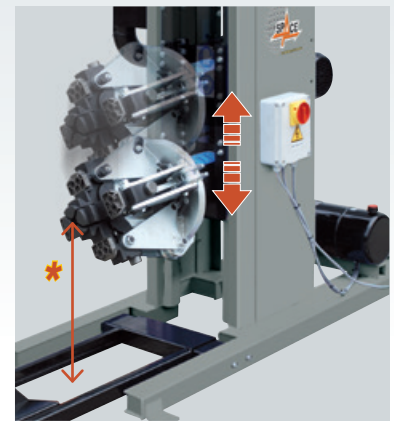

- * MINIMUM HEIGHT 330 mm (13")
- * MINIMUM CLAMPING Ø 90 mm (4")
- * HYDRAULIC UP-DOWN MOVEMENT



TUBE AND TUBELESS

GGRS926

GGRS926 SERIES

Smontagomme per servizio mobile o in officina

(IT)

Tyre changer for road-side and workshop service

(EN)

Montiergerät für den mobilen oder stationären Einsatz

(DE)

Démonte-pneus pour service mobile ou en atelier

(FR)

Desmontadora para servicio móvil o en el taller

(ES)

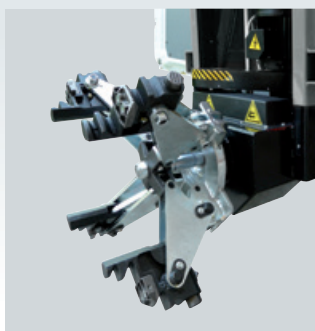

GGRS926 HYDRAULIC CLAMPING

Mandrin idraulico. Adatta anche a pneumatici agricoli.
Hydraulic chucking table. Suitable also for agricultural tyres.
Hydraulische Spannvorrichtung. Geeignet auch für Landwirtschaftsräder.
Mandrin hydraulique. Apte aussi au pneus agricoles.
Plato mandril hidráulico. Puede ser utilizada con ruedas agrícolas también.

EASY SETTING

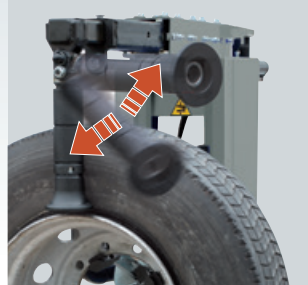

OPTIONS



G108A2
Alu Protection (4 X Kit)



G90A6
Alu Rim Clamp



G108A22
Disc for wheels with lock ring

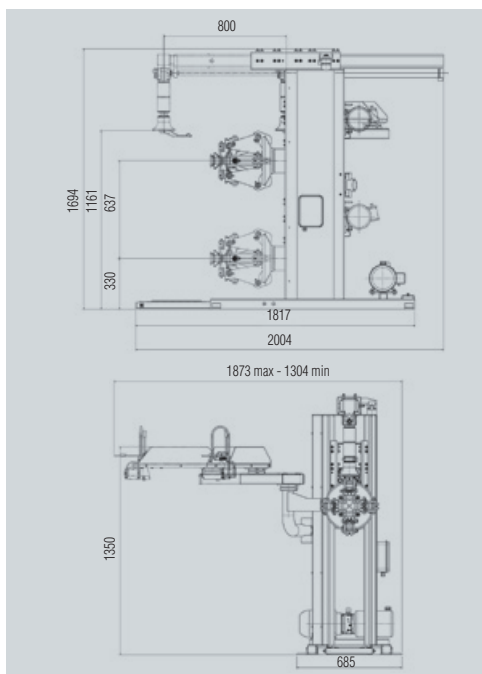

DATI TECNICI	TECHNICAL DATA	TECHNISCHE DATEN	DONNEES TECHNIQUES	DATOS TÉCNICOS	GGRS926
Motore rotazione mandrino	Chucking unit rotation motor	Motor für Drehung der Spannvorrichtung	Moteur rotation mandrin	Motor rotación plato	1,1 kW
Motore centralina	Hydraulic drive unit motor	Hydraulikmotor	Moteur de la pompe	Motor unidad hidráulica	2 kW
Ø cerchi	Rim Ø	Felgen-Ø	Ø de la jante	Ø de llantas en pulgadas	11"-27"
Ø est. ruota ammesso	Max. wheel Ø	Raddurchmesser	Ø de la roue	Ø maximo ext. rueda	1300 mm (51")
Larghezza max. ruota	Max. allowed wheel width	Max. Radbreite	Largeur maxi de la roue	Ancho max. rueda	950 mm (37.4")
Peso	Weight	Gewicht	Poids	Peso	378 kg/833 lb
Potenza stallatore	Bead breaker power	Abdrückerkraft	Force du détalonneur	Force du détalonneur	16000 N
Peso max ruota	Max wheel weight	Maximales Radgewicht	Poids maxi de la roue	Poids maxi de la roue	1200 kg/2645 lbs
Velocità di rotazione mandrino (giri/min)	Chuck rotation speed (rev/min)	Sperrvorrichtungsdrehgeschwindigkeit (U./min.)	Vitesse de rotation du mandrin (tours/min.)	Velocidad de rotación mandril (rev./min.)	8
Coppia max al mandrino	Max. torque to chuck	Max. Sperrvorrichtungs-Drehmoment	Couple max. au mandrin	Par máx al mandril	1700 Nm (1253 FtLbs)

SPACE s.r.l. a s.u.

Via Sangano, 48
10090 Trana - Torino - ITALY
tel. +39-011-934.40.300
fax +39-011-933.88.64
e-mail: info@spacetest.com
www.spacetest.com