

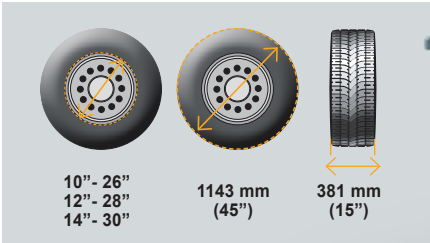

good energy
POWERED BY LAST GENERATION POWER INVERTER



COMPLETAMENTE SENZA LEVA
COMPLETELY LEVERLESS
KOMPLETT HEBELLOS
COMPLÈTEMENT SANS LEVIER
TOTALMENTE SIN PALANCA



GA560.30 GIOTTO

**Smontagomme
senza leva**

(IT)

**Leverless tyre
changers**

(EN)

**Hebellose
Reifenmontiergeräte**

(DE)

**Démonte-pneus
sans levier**

(FR)

**Désmontadoras
sin palanca**

(ES)

INTUITIVE CONTROLS



SYNCRO ROLLERS



Lo stallonamento viene fatto tramite due rulli con movimento sincronizzato. Lato superiore e inferiore vengono stallonati da due rulli opposti in rapida successione.

The bead-breaking is performed by means of two rollers with a synchronized movement. The bead-breaking of both sides is quickly performed.

Der Reifen wird mittels zwei Abdrückrollen vollzogen mit Synchronlauf. Die untere und obere Wulst werden sukzessiv von zwei gegenüberliegenden Rollen schnell und sicher abgedrückt.

Le détalonnage se fait par le biais de deux rouleaux avec mouvement synchronisé.

Le haut et le bas sont rapidement détalonnés l'un après l'autre par deux rouleaux opposés.

El destalonado es por dos rodillos en forma de disco con movimiento sincronizado. Los dos lados, superior e inferior, se destalonan por medio de los dos rodillos opuestos y en sucesión rápida.

EASY DEMOUNTING

**PATENTED
BREVETTATO**

EASY MOUNTING



L'utensile si inserisce fra tallone e cerchio.

The tool enters between bead and rim.

Die Montagevorrichtung dringt zwischen Wulst und Felge ein.

Le dispositif se place entre le talon et la jante.

El útil se inserta entre el talón y la llanta.



Facendo leva sul cerchio, l'utensile solleva il tallone con il minimo stress.

Levering on the rim, the tool pulls up the bead, minimising the stress.

Diese drückt gegen die Felge und hebt somit mit min. Stress den Wulst hoch.

Le dispositif fait levier sur la jante et soulève le talon avec un effort minime.

Apalancando encima de la llanta, la herramienta eleva el talón con el mínimo esfuerzo.



Il tallone viene sollevato progressivamente.

The bead is progressively pulled up.

Der Wulst wird schrittweise hochgehoben.

Le talon est soulevé petit à petit.

El talón se eleva progresivamente.



- 10"-26"
- 12"-28"
- 14"-30"



ADJUSTABLE LOCKING

Base estendibile a 3 posizioni.

3-position extendable base.

Auf 3 Positionen erweiterbare Basis.

Base extensible à 3 positions.

Base extensible de 3 posiciones.

REVERSE WHEEL FAST LOCKING

Bloccaggio centrale, idoneo anche per ruote rovesce. Lo sforzo è minimo grazie allo speciale piattello di appoggio ruota, di tipo flottante con effetto autobloccante.

Central rim locking system, suitable also for reverse rims.

The stress is minimal thanks to the special plate on which the wheel lays. The plate is floating, therefore offering a self-locking mechanism.

Die Zentrale Spannvorrichtung ist auch für umgekehrte Felgen geeignet. Das Radspannen erfolgt dank einer selbstarretierender Radscheibe schnell und mit min. Kraftaufwand.

Le blocage central est idéal également pour les roues renversées. L'effort est minime grâce à un support de roue très spécifique, de type plateau flottant avec effet autobloquant.

Bloqueo central, idóneo perfectamente para ruedas normales y reversas. El esfuerzo es mínimo debido al especial platillo de apoyo de la rueda, de tipo flotante con efecto de auto-bloqueo.

**PATENTED
BREVETTATO**



EXCLUSIVE
SELF-LOCKING PLATE



FLANGE NOT
REQUIRED



Versione con gonfiatubeless brevettato
Version with patented inflation device
 Version mit patentierter TOP-Reifenfüllvorrichtung
Version avec système de gonflage tubeless breveté TOP
 Versión de inflado tubeless TOP, amparado por patente.

GA560.30 IT

INVE MOTOR

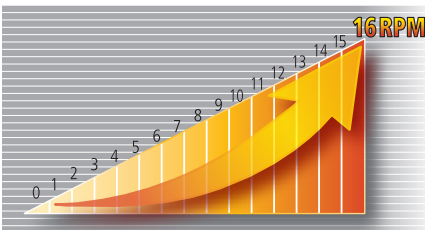

Il motore opera tramite un inverter esclusivo di ultima generazione che:

- permette di regolare a piacere la velocità di rotazione tramite il pedale
- rallenta automaticamente la rotazione con l'aumentare dello stress sul tallone (per evitare danni al pneumatico)

The electrical motor is equipped with an exclusive and innovative inverter, which:

- allows to regulate the chucking table rotation speed by pressing the pedal
- slows down the rotation speed as the stress on the bead increases (to avoid any damage to the tyre)

Der Motor arbeitet mit einem speziellem Schalter letzter Generation:

- Dieser ermöglicht durch einfachen Pedaldruck die

Drehgeschwindigkeit zu steuern

- Verlangsamt automatisch die Drehung bei ansteigendem Stress auf dem Wulst. (um Reifenschäden zu vermeiden)

Le moteur est alimenté par une commande à fréquence variable exclusive, de dernière génération, qui:

- permet de régler la vitesse de rotation par l'intermédiaire de la pédale;
- ralentit automatiquement la rotation en cas d'augmentation de l'effort sur le talon (pour éviter d'endommager le pneu).

El motor opera mediante un inverter esclusivo de última generación que:

- permite regular, según se precise, la velocidad de rotación usando el pedal
- desacelera automáticamente la rotación al aumentar el esfuerzo sobre el talón (para prevenir daños al neumático).

STANDARD



G1000A140

Spingi tallone con trascinatore
Bead pusher with pulling system
 Wulstboy mit Zugvorrichtung
Pousse-talon avec traction
 Empujador de talones con tracción



Protezione cono
Cone guard
 Kegelschutz
Protection cône
 Protección del cono



Protezione piatto
Turntable guard
 Tellerschut
Protection plateau
 Protección del plato



Bloccaggio meccanico
Mechanical clamping
 Mechanische Aufspannung
Blocage mécanique
 Bloqueo mecánico

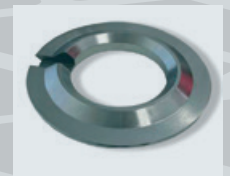

Adattatore centraggio
Centering adaptor
 Adapter für
Adaptateur centrage
 Adaptor para centrar

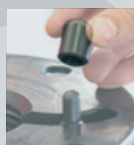

Prolunga e protezione trascinatore
Extension and guard
 Verlängerung und Schutz
Rallonge et protection
 Alargo y protección



Gonfiaggio rapido a pedale con manometro
Pedal operated quick inflation with gauge
 Pedalgesteuerte Reifenfüllvorrichtung mit Manometer
Gonflage rapide à pédale avec manomètre
 Inflado rápido con pedal y manómetro

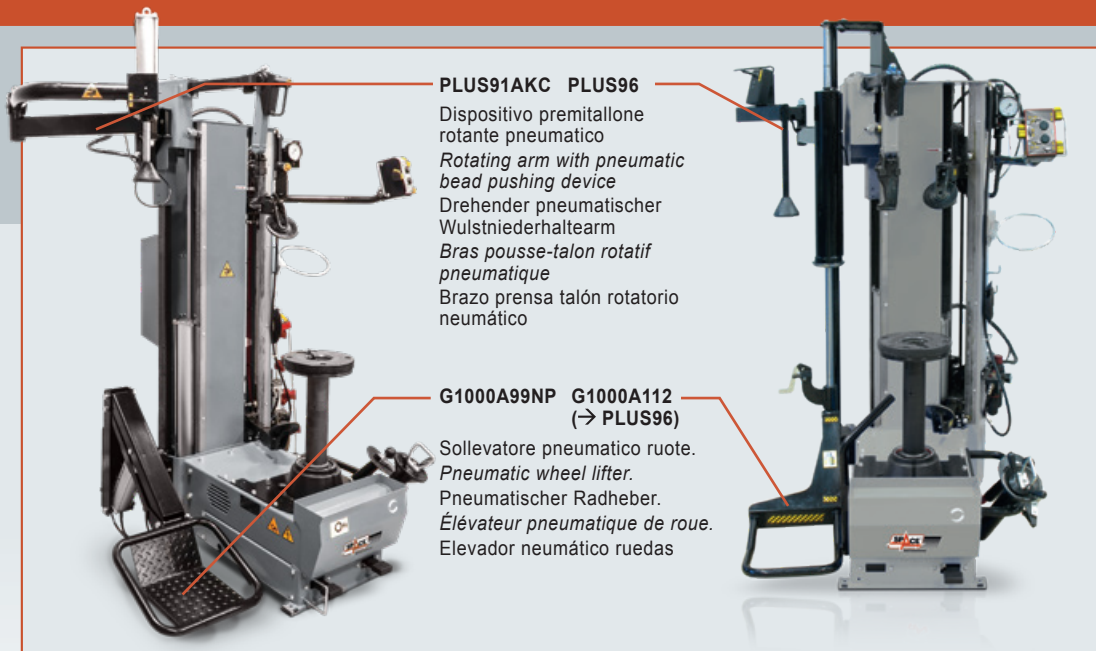

PLUS91AKC PLUS96

Dispositivo premitallone rotante pneumatico
Rotating arm with pneumatic bead pushing device
 Drehender pneumatischer Wulstniederhalterarm
Bras pousse-talon rotatif pneumatique
 Brazo prensa talón rotatorio neumático

G1000A99NP G1000A112 (→ PLUS96)

Sollevatore pneumatico ruote.
Pneumatic wheel lifter.
 Pneumatischer Radheber.
Élévateur pneumatique de roue.
 Elevador neumático ruedas



G1000A111 (→ PLUS96)
 Pressore sagomato WDK.
WDK bead pressure device.
 WDK-Wulstniederhalter.
Outil de pression spécial conforme à la norme WDK.
 Presor WDK.



G1000A138
 Bloccaggio rapido
Quick-fit locking
 Schnellspannung
 Blocage rapide
 Bloqueo rapido



G1000A137
 Flangia universale per ruote senza foro centrale e adatta anche a ruote rovesce
Universal flange for closed centre, adapted also for reverse rims.
 Universalfansch für Räder mit Blindbohrungen, geeignet auch für Reverse-Rim-Design.
Bride universelle pour roues à trous aveugles, indiquée aussi pour roues à gorge renversée.
 Brida universal para ruedas sin agujero central (llantas ciegas) y adapta por ruedas reversas.



G1000A66K (5 x kit)
 Protezione cono di bloccaggio
Set of protections of locking cone
 Satz Schutz Zugvorrichtung
Kit protections cône dispositif de blocage
 Juego protecciones cono



G1000A70K (5 x kit)
 Protezione trascinate
Set of protections for pulling unit
 Satz Schutz Zugvorrichtung
Kit protections dé d'entraînement
 Juego protecciones arrastrador



G1000A81K (10 x kit)
 Protezione ruote rovesce in gomma
Set of rubber protections for support plate
 Satz Scheiben-Schutz (Gummi)
Kit protections plateau en caoutchouc
 Juego protecciones platillo en goma

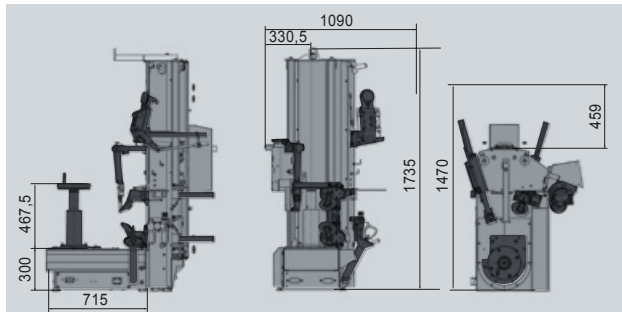

Dati tecnici	Technical Data	Technische Daten	Donnees Techniques	Datos técnicos	
Lavora su ruote da	<i>Handles wheels from</i>	Geeignet für Räder	<i>Fonctionne sur roues de</i>	Funciona en ruedas de	10"-26" / 12"-28" / 14" - 30"
Peso	<i>Weight</i>	Gewicht	<i>Poids</i>	Peso	330 kg (338 kg IT)
Larghezza max ruota	<i>Max wheel width</i>	Radbreite, max.	<i>Largeur max. roue</i>	Anchura máx. rueda	15"
Diam. max ruota	<i>Max wheel diam.</i>	Raddiameter, max	<i>Diamètre max roue</i>	Diám. máx. rueda	45"
Forza di stallonatore (ogni rullo)	<i>Bead break.pov. (each arm)</i>	Abdrückkraft (jeder Arm)	<i>Force décol. talon (chaque bras)</i>	Fuerza de destal. (braz.)	1200 kg
Coppia max	<i>Max torque</i>	Drehmoment, max	<i>Couple max.</i>	Par máximo	120 Kgm
Movimento di stallonam.	<i>Bead breaker mouvement</i>	Abdrückbewegung	<i>Mouv. décol. talon</i>	Movim. de destalonam. automatic	
Motore di rotazione	<i>Rotation Mot or</i>	Motor Drehung	<i>Moteur de rotation</i>	Motor de rotación	1,5 Kw inverter motor +0,75 Kw motor
Pressione raccomandata	<i>Recommended air supply</i>	Empfohlener Druck	<i>Pression recommandée</i>	Presión recomendada	8 - 10 bar
Voltaggio	<i>Power Supply</i>	Voltage	<i>Voltage</i>	Electricidad	1ph, 200/265v, 50/60Hz

SPACE s.r.l. a s.u.

Via Sangano, 48
 10090 Trana - Torino - ITALY
 tel. +39-011-934.40.300
 fax +39-011-933.88.64
 e-mail: info@spacetest.com
 www.spacetest.com

Le caratteristiche tecniche e gli allestimenti presentati in questo prospetto possono subire variazioni. Le immagini riprodotte non sono vincolanti.
Technical data and composition presented in this catalogue may vary. Pictures reproduced are only indicative.
 Die techn. Daten und die Ausrüstungen, die in diesem Prospekt enthalten sind, können Änderungen erfahren. Deshalb sind die Abbildungen unverbindlich.
Les caractéristiques techniques et les compositions présentées dans ce prospectus peuvent subir des variations. Les images reproduites n'ont qu'une valeur indicative.
 Las características técnicas y las composiciones ilustradas en este folleto pueden sufrir variaciones. Las imágenes propuestas son solamente indicativas.